

Castellar

Surface Mounted, Wall Light



The Castellar is a square shaped wall mounting luminaire, with a white dry powder coated steel base and curved polycarbonate diffuser and steel frame secured by four decorative chromed bolts. Slotted side panels also offer a back light onto the mounting surface.

White dry powder coated mild steel base/diffuser frame

Opal polycarbonate diffuser

Secured by decorative chrome bolts

Slotted side panels in the base give a back light to the side of the luminaire

50,000 hours life

HILCLARE

LIGHTING MANUFACTURER

— LED BY DESIGN —

a  pilot group company

T: 0161 274 3626
F: 0161 274 3731
E: sales@hilclare.com

15 Carnarvon Street
Manchester
M31HJ

Ordering Information

	Code	Weight (kg)	Total Watts	Total Lumens	Luminaire Efficacy	IP Rating	Life	Warranty
14W	SDC14T340	0.95	14	1254	56	IP20	50,000hr	5 year

Code Builder

Microwave sensor – Add MS9
 Microwave corridor version – Add MS9MD
 Emergency – Add EM
 Colour 3000K – Add 30
 Dali dimming – Add DA

Dimensions

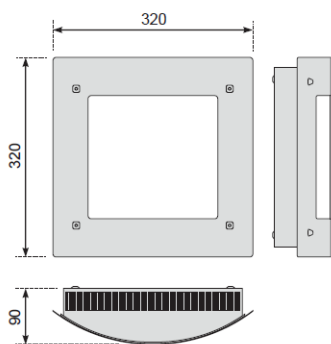

Photometrics

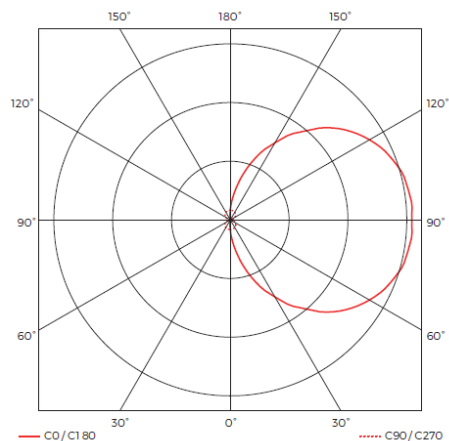

Classification of Protection

Against electric shock Class 1 protected with earthed metalwork. Against ingress of dust and moisture IP20 Technical Specification.

Standards

The Castellar range of luminaires is designed and manufactured to meet the requirements of BSEN 60598 2-1.

Operations

Designed for operation in an interior environment. Ambient temperature range: -5°C to +25°C.
 230V 50Hz nominal input voltage.

Specification

The Castellar is a square shaped wall mounting luminaire, with a white dry powder coated steel base and curved polycarbonate diffuser and steel frame secured by four decorative chromed bolts. Slotted side panels also offer a back light onto the mounting surface.

Version 1 October 2018

HILCLARE
 LIGHTING MANUFACTURER
 — LED BY DESIGN —

a pilot group company

T: 0161 274 3626
 F: 0161 274 3731
 E: sales@hilclare.com

15 Carnarvon Street
 Manchester
 M3 1HJ

E&OE